

FLAT PLATE WASHERS – CHEAT SHEET

P1019 & P1020 FLAT PLATE FITTING

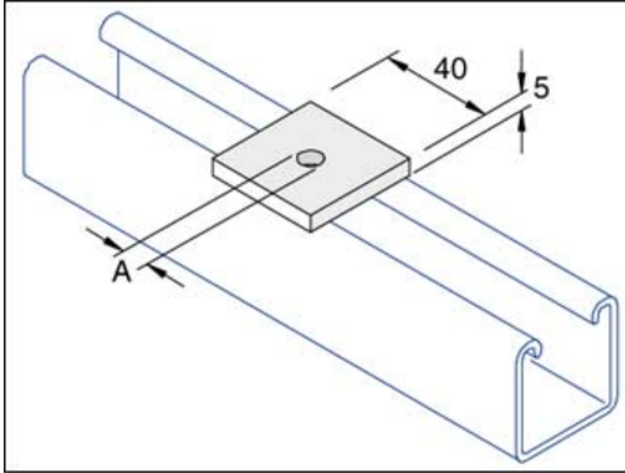

Standard Dimensions:

The following are standard dimensions unless otherwise stated.

All dimensions subject to commercial tolerance.

- Hole Spacing (From End):
20mm from end of fitting
- Fitting Width: 41mm

Dimensions shown are for mild steel components only.
Dimensions for stainless steel components may vary.

Part No.	Fin.	Size	A	Wt.	Box Qty
P1019	HG	M6/8	9	0.06	100
P1020	HG	M10/12	13	0.06	100
P1019	SS	M6/8	9	0.06	100
P1020	SS	M10/12	13	0.06	100

P1063 FLAT PLATE FITTING

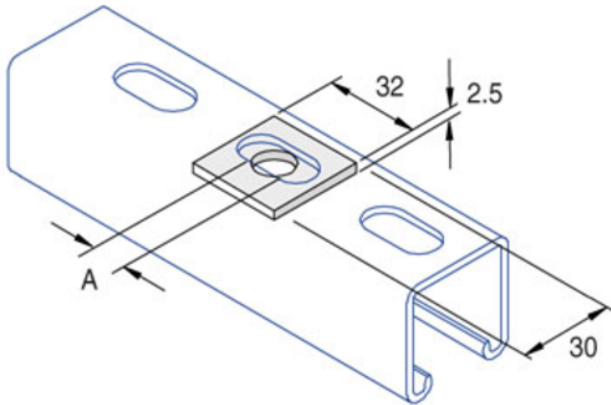

Standard Dimensions:

The following are standard dimensions unless otherwise stated.

All dimensions subject to commercial tolerance.

Dimensions shown are for mild steel components only.
Dimensions for stainless steel components may vary.

Part No.	Fin.	Size	A	Wt.	Box Qty
P1063/06	PG	M6	8	0.02	100
P1063/08	PG	M8	10	0.02	100
P1063/10	PG	M10	12	0.02	100
P1063/12	PG	M12	14	0.02	100
P1063/06	SS	M6	8	0.02	100
P1063/08	SS	M8	10	0.02	100
P1063/10	SS	M10	12	0.02	100
P1063/12	SS	M12	14	0.02	100

P1062T, P1062AT, P1063T, P1064T DOMED FLAT PLATE FITTING

Size M6, M8, M10, M12

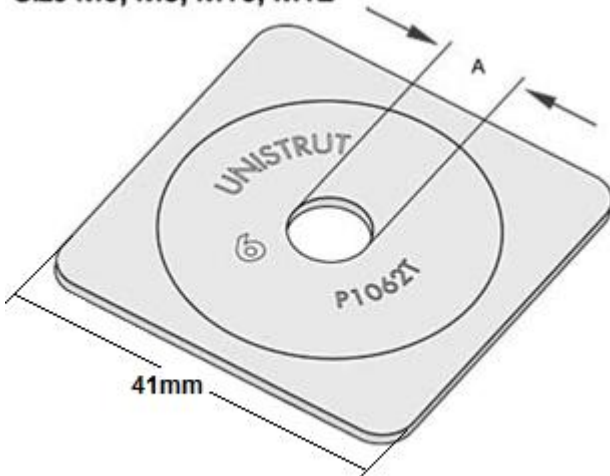

Standard Dimensions:

The following are standard dimensions unless otherwise stated.

All dimensions subject to commercial tolerance.

- Hole Spacing (From End):
20mm from end of fitting
- Fitting Width: 41mm

Dimensions shown are for mild steel components only.
Dimensions for stainless steel components may vary.

Part No.	Fin.	Size	A	Wt.	Box Qty
P1062AT	PG	M8	10	0.03	100
P1062T	PG	M6	8	0.03	100
P1063T	PG	M10	12	0.03	100
P1064T	PG	M12	14	0.03	100